



LIMITED WARRANTY

PerTronix, Inc. warrants to the original Purchaser of its solid-state ignition system (product) that the Ignitor shall be free from defects in material and workmanship for a period of (30) months from the date of purchase.

If within the period of the foregoing warranty PerTronix finds, after inspection, that the product or any component thereof is defective, PerTronix will, at its option, repair such products or component or replace them with identical or similar parts PROVIDED that within such period Purchaser:

1. Promptly notifies PerTronix, in writing, of such defects.
2. Delivers the defective products product or component to PerTronix (Attn: Warranty) with proof of purchase date; and
3. Has installed and used the product in a normal and proper manner, consistent with PerTronix printed instructions

THE FOREGOING LIMITED WARRANTY IS EXCLUSIVE AND IN LIEU OF ALL OTHER WARRANTIES, WHETHER EXPRESS OR IMPLIED, INCLUDING ANY IMPLIED WARRANTY OR MERCHANTABILITY OR FITNESS FOR A PARTICULAR PURPOSE.

THE FURNISHING OF A REPAIR OR REPLACEMENT COMPONENTS SHALL CONSTITUTE THE SOLE REMEDY OF PURCHASER AND THE SOLE LIABILITY OF PerTronix WHETHER ON WARRANTY, CONTRACT OR FOR NEGLIGENCE, AND IN NO EVENT WILL PerTronix BE LIABLE FOR MONEY DAMAGES WHETHER DIRECT OR CONSEQUENTIAL.



440 East Arrow Highway
San Dimas, California 91773
(909) 599-5955



INSTALLATION INSTRUCTIONS FOR 6 VOLT POSITIVE GROUND APPLICATIONS



Read all instructions before attempting to install...

- For 6-volt positive ground systems.
- Compatible with "points style" coils.
- Do not use "HEI" type coils.

1. Turn the ignition switch off or disconnect the battery.
2. Remove the distributor cap and rotor. Do not disconnect the sparkplug wires.
3. Examine the cap and rotor for wear or damage. Replace as needed.
4. Remove the points, condenser, and grommet.
5. The Ignitor does not require any modification to the distributor. Therefore the points, condenser and hardware can be used as backup.
6. Clean any oil or dirt from the breaker plate and point cam.
7. Install the Ignitor plate onto the breaker plate, and fasten it in place.
8. If the distributor ground wire was removed during the installation process, be sure to re-attach it securely.
9. Install the magnet sleeve over distributor shaft and onto the point cam. Rotate sleeve until a slight locating position is felt before applying pressure. With sleeve lined up on point cam, press down firmly insuring the sleeve is fully seated.
10. Insert both wires through the hole in the distributor housing. Pull the grommet into place. Make sure that the wires do not interfere with any moving parts.
11. Replace the rotor and distributor cap. Make sure that all spark plug wires are attached securely.
12. Remove the ignition switch wire from the negative coil terminal. Connect the black Ignitor wire directly to the ignition switch wire.
13. Connect the Ignitor black/white wire to negative (-) side of the ignition coil.
14. Connect an insulated, AWG 20 copper stranded wire from the positive coil terminal to the positive battery or chassis.
15. The black/white Ignitor wire and the AWG 20 copper wire should be the only wires connected to the coil.
16. Reconnect the battery and make sure all wires are connected correctly.
17. The engine can now be started. Let the engine run for a few minutes and then set the timing in the conventional manner.

Ignitor™ COMMON QUESTIONS AND ANSWERS

- Q. What is the first thing I should check if the engine would not start?**
A. Make certain all wires are connected securely to the proper terminals.

- Q. What type of coil can I use?**
A. The Ignitor™ is compatible only with a "points style" coil.

- Q. What happens if I leave the ignition switch on when the engine is not running?**
A. This can cause you coil to overheat, which may cause permanent damage to the coil and the Ignitor™.

- Q. May I modify the length of the Ignitor™ wires?**
A. Yes, you may cut the wires to any length your application may require. You may also add lengths of wire if needed (20 gauge wire). Please make sure all wire splice are clean and connections are secure.

- Q. How can I get additional help?**
A. Call our tech line (800 827 3758) for any further instructions or questions. You may also logon to www.pertronix.com for the latest technical information.

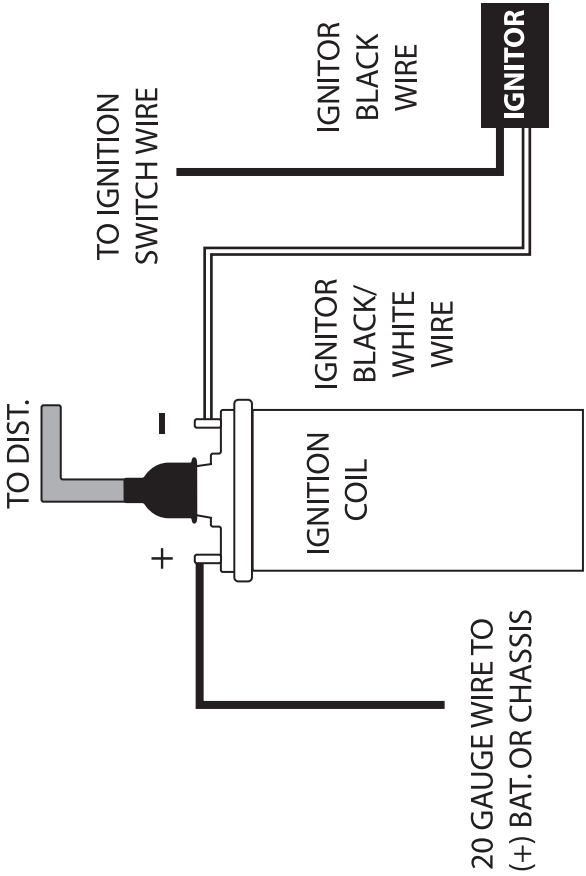

WIRING DIAGRAM FOR SYSTEMS WITHOUT BALLAST RESISTORS